

40x40x20mm

Model H

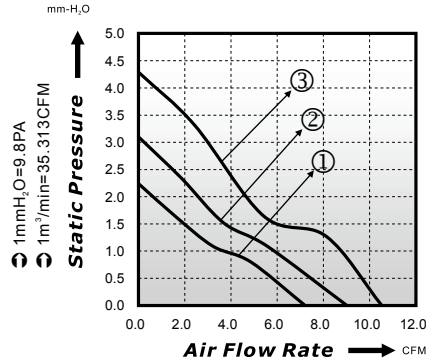

P-Q Curve (At Rated Voltage)



Dimensions Drawing

Unit: (mm)

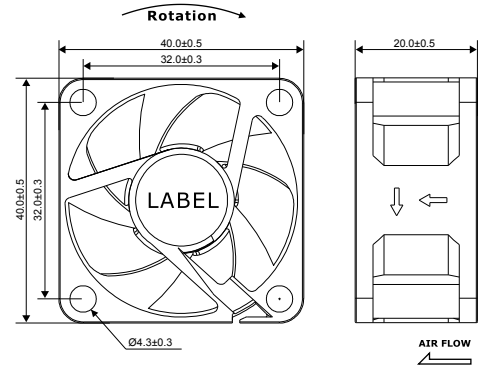

Model No	Bearing (*)	Rated Voltage (VDC)	Rated Current (A)	Power Consumption (Watts)	Speed (rpm)	Air Flow (CFM)	Static Pressure (mmH ₂ O)	Noise (dBA)	Curve
ED04020-05L*	○ ⊖	5	0.16	0.80	5000	7.21	2.24	19.7	1
ED04020-05M*	○ ⊖	5	0.19	0.95	6000	9.02	3.10	23.9	2
ED04020-05H*	○ ⊖	5	0.22	1.10	7200	10.53	4.29	29.6	3
ED04020-12L*	○ ⊖	12	0.067	0.80	5000	7.21	2.24	19.7	1
ED04020-12M*	○ ⊖	12	0.079	0.95	6000	9.02	3.10	23.9	2
ED04020-12H*	○ ⊖	12	0.091	1.09	7200	10.53	4.29	29.6	3

* Bearing Type: ○ Sleeve ● Two Ball ⊖ Hydro-Dynamic